



Yocell Biotechnology (Qingdao) Co., LTD

Add.: No. 176 Jufeng Road, 266199, Qingdao, China

Tel.: +86 532 80920900

Email: info@yocellbio.com

Web: www.yocellbio.com



Fast Protein Liquid Chromatography (FPLC)



www.yocellbio.com

About us

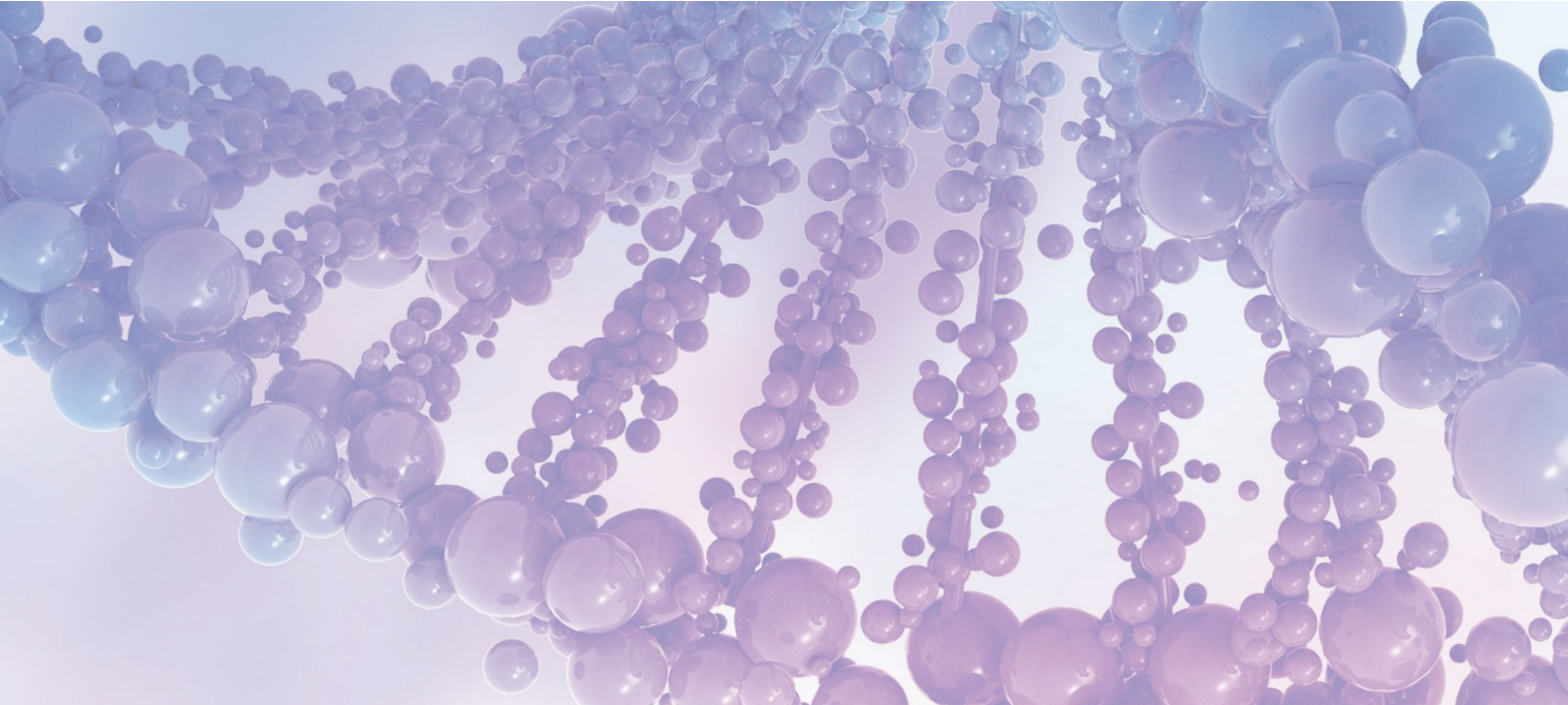

YOCELL Biotechnology is your trusted partner in the field of bioprocess. YOCELL has a team of energetic young scientists and engineers. From initial R&D to production, we are committed to providing the most reliable solutions for biotechnology scientists and engineers around the world. Accepting the challenges of continuous innovation in biotechnology and solving problems from multiple perspectives are the most impressive qualities of the team.

Pragmatic

Always listen carefully to your needs and provide the most competitive solutions.

Efficient

Respond quickly and have a strong supply chain to ensure fast delivery.

Focus

Continuous attention and passion for innovation in the field of biotechnology control.

Contents



From laboratory to production Protein Purification Solutions

We are the industry leader for protein purification device. We have full variety of instrument solutions to support all your needs. We design, develop and service to ensure the top gear instrument ready for your next idea.

SDA: The brand-new cost-saving solution

SCG-P: Flagship high performance solution

SCG: The classic flexible solution

SCG-Q: The quad time-saving solution

SDL: The all-in-one space saving solution

SCG-Phf: The entry to massive production

SCG-D: The duo time-saving solution

SCI: Ultimate time-saving solution

STS (Sepure True Synt) Oligonucleotide Synthesis System

STS is the all-in-one solution for oligonucleotide (DNA/RNA) synthesis. Fully automated suitable for all kind of laboratory usage.

Chromatography Column Kit

Empty Chromatography Column Kit suitable for low-pressure process development, including recombination proteins, antibodies, vaccines, and blood related products. It also suit for antibiotics, peptides, synthetic drugs, and natural medicine.

Accessories

A wide variety accessories for your applications, including injection loop, pipe(PEEK/PFA), liquid mixture, etc.

System features

Reliable high-quality builds

- The main components are manufactured by the world-renowned manufacturers, with close collaborations in product development and rigorous testings. The performance and reliability is thus ensured. All material in contact with sample path are bioinert materials with proven biocompatibilities.

Stable while precise liquid flow rate

- Gradient pump modules with two quality dual plunger pumps with easy access PEEK pump head allows convenient cleaning/ maintenance.
- Self-flushing feature available to prevent the damages or contaminations due to biomedical sample/salt contact during operations. Electronic pulsation inhibition feature available to ensure the precision and repeatability for ramp gradient performance, ensuring the repeatability for purification results.

Accurate in-time measurement result

- UV absorbance module with quality ensured DAD monitoring absorbance signal in multiple wavelength channel, providing capability to monitor in-time fraction purity.
- pH/conductivity sensor with compensate capability from temperature result, providing easy access to accurate in-time measurement result .

Flexible flow path control

- A wide variety of flow valves designed to ensure the flexible also accurate flow path control, including but not limited to input selection valve, collection valve, column selection valve, sample injection valve, column selection valve, etc. Collaborated designs with world-renowned manufacturers to address every customers' need.

Dynamic smart sample collection solutions

- Brand new designs of fraction collector, with multiple auto-detectable tube stands, supports every customer's need for purification target collection.



SDA protein purification system

2022 Brand new Protein Purification System - SDA series

- SDA is a medium-sized all-in-one system. It is the space saving solution while maintain the same modern appearance as SCG-P. Its automation capability can be greatly extended through the additional valve installed externally. SDA is a high performance-to-cost ratio product introduced to meet various customers' need.
- Powerful SCG operation software offer intuitive and flexible method editor, system controller and data analysis tool. Please note that the operating software is free for upgrade during the product lifetime.
- Can work with various brand chromatography column from domestic or international suppliers.
- SDA-030 can satisfy milligram level purification need; SDA-100 can satisfy gram level purification need.

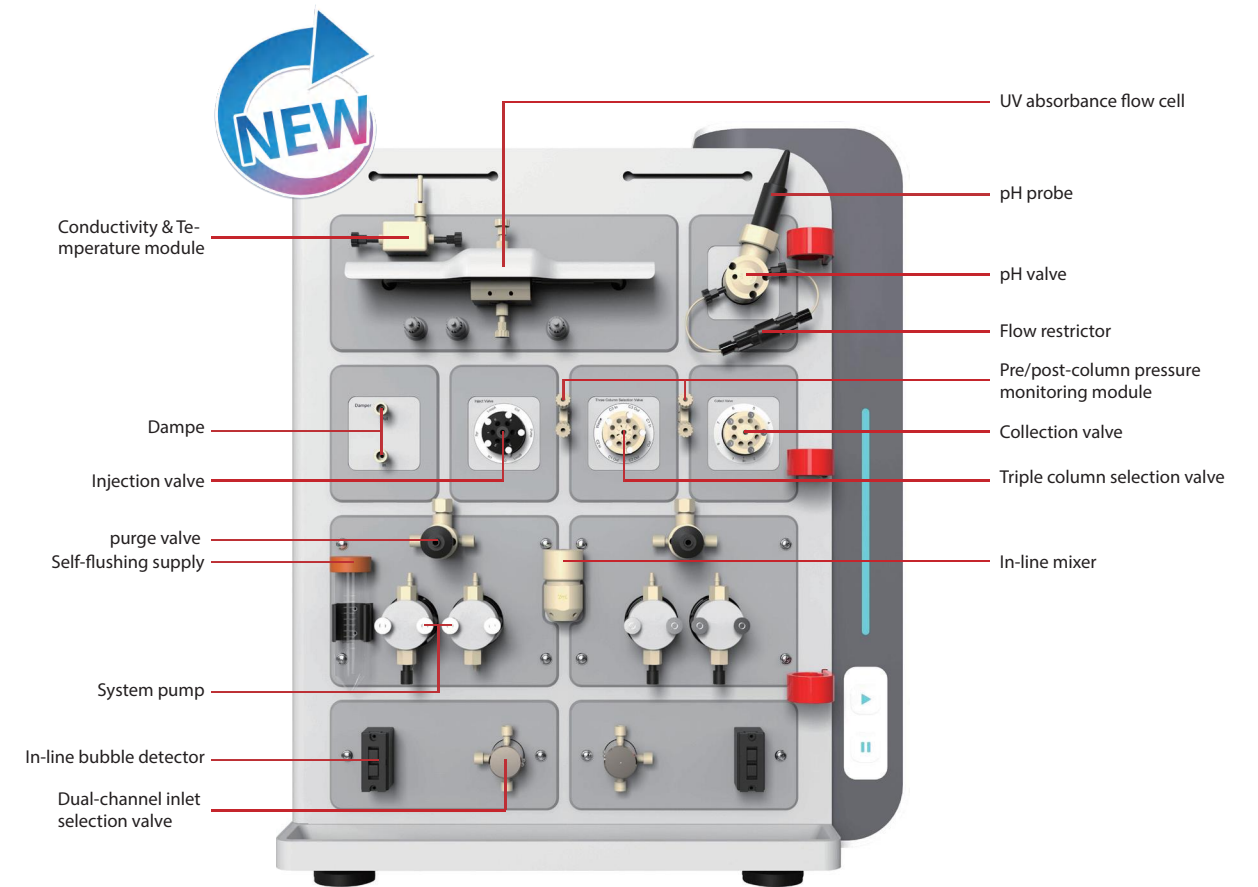

Technical parameter

Model	SDA-030	SDA-100	SDA-300
System pump	Two dual plunger pumps, bioinert PEEK material, provides stable while precise flow rates		
Flow rate range	0.001-36 ml/min	0.01-100 ml/min	0.1 – 300 ml/min
System pressure rate	0-27 MPa (270bar, 4000psi)	0-10 MPa(100bar, 1450psi)	0-6.8 MPa(68bar, 1000psi)
Mixer	In-line mixer, standard size: 2ml (Optional: 0.6ml/5ml)		5ml in-line mixer
Flow rate accuracy	±1.2%		± 2%
Flow rate precision	RSD<0.5%		
Supported elution	Isocratic/ramp/step gradient, in-process modification available		
UV-absorbance module	Default 260 & 280 nm detector, detecting both channels simultaneously. Wavelengths customizable when ordering, including 2.0mm external flow cell		
Wavelength precision/repeatability	±1nm / ±0.5nm		
UV noise / drift	0.16 mAu(1s)/ 1 mAu/h		
Conductivity sensor	0.001-999.99 mS/cm, precision ±0.1 mS/cm or ±2%		
Temperature sensor	0-100 °C, precision± 1 °C, can compensate conductivity/pH result automatically		
Inlet selection module	Two buffer entry for each pump: A1/A2, and B1/B2		
Automatic sample injection valve	5-position-7-port valve, the software controls the switching of the sampling valve.Support Load, Inject, Waste, functions.support quantitative loop or quantitative cup injection; 1ml loop		
Dual channel mobile phase selection module	A/B pumps each provide two buffer inlets,A1/A2, B1/B2 (for SDA-030/100)		
System operation workstation	SCG operation workstation: in-house designed operation software, brand computer with Win10 operating system		
Installation toolkit	PEEK / PTFE pipe, installation manual, user manual, pipe joints, column clip, Flow restrictor, pre-column filter, 1 ml quantitative loop, common tools, etc.		
Solvent tray	The instrument come with a solvent tray on the top, access easy while saving space		
Sample contact material list	PEEK, Stainless Steel, PPS, PTFE		
AC input/ power rating	220VAC/400W		
Instrument weight (gross weight)	57kg		
Dimension (W×D×H)	565mm × 611mm × 523mm		

Optional Configuration

DAD400EX variable-dual-channel UV sensor	200 - 400 nm imported detector, detecting both channels simultaneously. Wavelengths configurable in software, including 2.0mm external flow cell
DAD400EX variable-quad-channel UV sensor	200 - 400 nm imported detector, detecting four channels simultaneously. Wavelengths configurable in software, including 2.0mm external flow cell
DAD600EX variable-quad-channel UV sensor	200 - 600 nm imported detector, detecting four channels simultaneously. Wavelengths configurable in software, including 2.0mm external flow cell
DAD800EX variable-quad-channel UV sensor	190 - 840 nm imported detector, detecting four channels simultaneously. Wavelengths configurable in software, including 2.0mm external flow cell
PH014 sensor system	Including pH measuring probe, flow cell, protection pool, control board, etc
Eight-channel inlet selection valve	Includes eight flow inlet buffer auto controlled by software(for SDA-030/100)
Six-channel inlet selection valve	Includes six flow inlet buffer auto controlled by software(for SDA-300)
In-line bubble detector	Control operation flow via detecting air bubbles in the pipeline
Pre-column pressure monitoring module	Monitor the pre-column pressure
Pre/post column pressure monitoring module	Monitor the pre-/post-column pressure
The CPV01B column-selection valve	Support for both the Column and Bypass auto switching function
The CPV01C column-selection valve	(Maximum pressure rate: 2 MPa) Support direct/reverse Column path and Bypass auto switching function
Three column-selection module	(Maximum pressure rate: 250 PSI) Support 3 Columns selection and Bypass auto switching function, one column position support column forward and reverse flushing function
Five column-selection module	(Has to work with SIS-CS5, SIS-CSV, SIS-HPCS5, or SIS-HSCSV) support column forward and reverse flushing function (for SDA-030/100)
Multi-column reverse flushing module	(Maximum pressure rate: 30 PSI) one waste position and one sample collection outlet (for SDA-030/100)
FV02 Dual-channel collection valve	(Maximum pressure rate: 250 PSI) one waste position and seven sample collection outlet
FV08 Eight-channel bulk collection valve	With two default 16mm collector racks (SIS-AFR1, 60 15ml-tube-locations), other choices available (one rack only if 96-well collector rack is used)
Fraction collector	With two default 16mm collector racks (SIS-AFR1, 60 15ml-tube-locations), other choices available (one rack only if 96-well collector rack is used)
13mm collector rack	One 13 mm rack with 90 * 5 ml tubes
16mm collector rack	One 16 mm rack with 60 * 15 ml tubes
28mm collector rack	One 28 mm rack with 21 * 50 ml tubes
96-well collector rack	One collector frame with four deep-hole 96-well plates
Wireless monitoring module	Wireless mobile terminal monitoring module
3Q certification	IQ/OQ/PQ

SCG-P Protein Purification System

- SCG-P is the premium all-in-one system. Power performance and flexible capability ready for all your needs.
- Sample pump add-on available.
- Flexible flow path add-on and sample pump add-on available.
- Carefully designed flow path to minimize the dead volume.
- More add-on expandability available for external valves or future upgrades.
- Powerful SCG operation software offer intuitive and flexible method editor, system controller and data analysis tool.

Please note that the software is free for upgrade during the product lifetime.

- Can work with various brand columns from domestic or international vendors.
- Can fit in regular chromatography refrigerator.
- SCG-P-030 can satisfy milligram level purification need; SCG-P-100 can satisfy gram level purification need; SCG-P-300 and etc can satisfy further scale up needs.

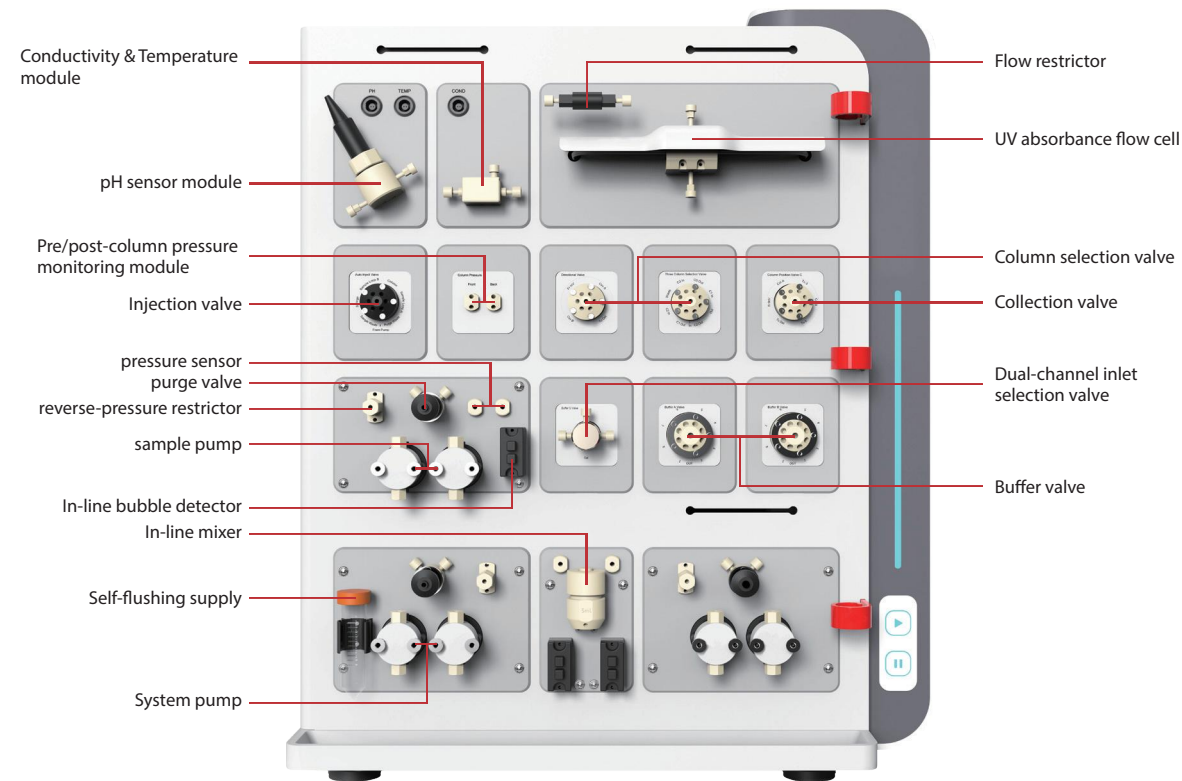

Technical parameter

Model	SCG-P-030	SCG-P-100	SCG-P-300
System pump	Two dual plunger pump, bioinert PEEK material, provides stable while precise flow rates		
Flow rate range	0.001 – 36 ml/min	0.01 – 100 ml/min	0.1 – 300 ml/min
System pressure rate	0-27 MPa (270bar, 4000psi)	0-10 MPa (100bar, 1450psi)	0-6.8 MPa (68bar, 1000psi)
Mixer	In-line mixer, standard size: 2ml (Optional: 0.6 ml / 5 ml)		5ml in-line mixer
Flow rate accuracy	± 1.2%		± 2%
Flow rate precision	RSD < 0.5%		
Supported elution	Isocratic/ramp/step gradient, in-process modification available		
UV-absorbance module	Default 260 & 280 nm detector, detecting both channels simultaneously. Wavelengths customizable when ordering, including 2.0mm external flow cell		
Wavelength precision/repeatability	±1nm / ±0.5nm		
UV noise/drift	0.16mAu(1s) / 1mAu/h		
Conductivity sensor	0.001 - 999.99 mS/cm, precision ±0.1mS/cm or ±2%		
Temperature sensor	0-100 C , precision± 1 C , can compensate conductivity/pH result automatically		
Automatic sample injection valve	5-position-7-port valve, the software controls the switching of the sampling valve. Support Load, Inject, Waste, SamplePumpWaste, SamplePumpDirect functions. support quantitative loop or quantitative cup injection; 1ml loop		
System operation workstation	SCG operation workstation: in-house designed operation software, brand computer with Win10 operating system		
Installation toolkit	PEEK / PTFE pipe, installation manual, user manual, pipe joints, column clip, Flow restrictor, pre-column filter, 1ml quantitative loop, common tools, etc.		
Solvent tray	The instrument come with a solvent tray on the top, access easy while saving space		
Sample contact material list	PEEK, Stainless Steel, PPS, PTFE		
AC input/power rating	220VAC/400W		
Instrument weight (gross weight)	72kg		
Dimension (WxDxH)	590mm × 740mm × 530mm		

Optional Configuration

DAD400EX variable-dual-channel UV sensor	200 - 400 nm imported detector, detecting both channels simultaneously. Wavelengths configurable in software, including 2.0mm external flow cell		
DAD400EX variable-quad-channel UV sensor	200 - 400 nm imported detector, detecting four channels simultaneously. Wavelengths configurable in software, including 2.0mm external flow cell		
DAD600EX variable-quad-channel UV sensor	200 - 600 nm imported detector, detecting four channels simultaneously. Wavelengths configurable in software, including 2.0mm external flow cell		
DAD800EX variable-quad-channel UV sensor	190 - 840 nm imported detector, detecting four channels simultaneously. Wavelengths configurable in software, including 2.0mm external flow cell		
PH014 sensor system	Including pH measuring probe, flow cell, protection pool, control board, etc.		
Duo-channel inlet selection valve	Includes two flow inlet buffer auto controlled by software(for SCG-P030/100)		
Eight-channel inlet selection valve	Includes eight flow inlet buffer auto controlled by software(for SCG-P030/100)		
Six-channel inlet selection valve	Includes six flow inlet buffer auto controlled by software(for SCG-P300)		
In-line bubble detector	Control operation flow via detecting air bubbles in the pipeline		
Pre-column pressure monitoring module	Monitor the pre-column pressure		
The CPV01B column-selection valve	Monitor the pre-/post-column pressure		
Pre/post column pressure monitoring module	Support for both the Column and Bypass auto switching function		
The CPV01C column-selection valve	(Maximum pressure rate: 2 MPa) Support direct/reverse Column path and Bypass auto switching function		
Three column-selection module	(Maximum pressure rate: 250 PSI) Support 3 Columns selection and Bypass auto switching function, one column position support column forward and reverse flushing function		
Five column-selection module	(Maximum pressure rate: 250 PSI) Support 5 Columns selection and Bypass auto switching function (for SCG-P030/100)		
Multi-column reverse flushing module	(Has to work with SIS-CS5, SIS-CSV, SIS-HPCS5, or SIS-HSCSV) support column forward and reverse flushing function (for SCG-P030/100)		
FV02 Dual-channel collection valve	(Maximum pressure rate: 30 PSI) one waste position and one sample collection outlet (for SCG-P030/100)		
FV08 Eight-channel bulk collection valve	(Maximum pressure rate: 250 PSI) one waste position and seven sample collection outlet		
Sample pump	0.001 – 36 ml/min	0.01 – 100 ml/min	0.1 – 300 ml/min
SV08 Sample selection valve	Supports 7 sample portals, one buffer, and is biocompatible (for SCG-P030/100)		
SV06 Sample selection valve	Supports 5 sample portals, one buffer, and is biocompatible (for SCG-P300)		
Fraction collector	With two default 16mm collector racks (SIS-AFR1, 60 15ml-tube-locations), other choices available (one rack only if 96-well collector rack is used)		
13mm collector rack	One 13 mm rack with 90 * 5 ml tubes		
16mm collector rack	One 16 mm rack with 60 * 15 ml tubes		
28mm collector rack	One 28 mm rack with 21 * 50 ml tubes		
96-well collector rack	One collector frame with four deep-hole 96-well plates		
Wireless monitoring module	Wireless mobile terminal monitoring module		
3Q certification	IQ/OQ/PQ		

Laboratory Protein Purification System Flow Diagram

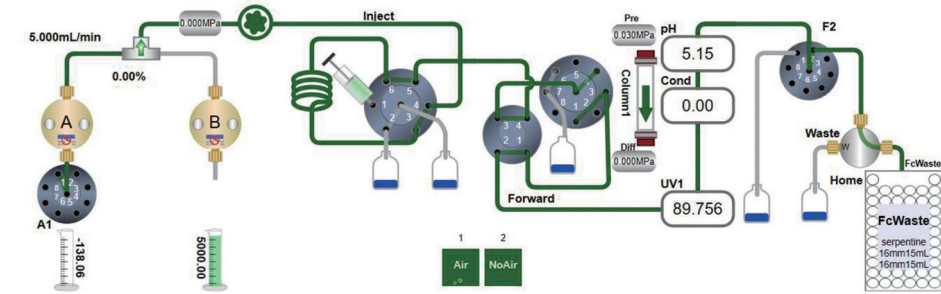

Despite the flow rate, all systems (36 ml/min, 100 ml/min, 300 ml/min) support injection through the sample loop. The illustrated system includes duo pumps, a fraction collector, a pH sensor, a conductivity sensor, a UV absorbance sensor and a temperature sensor. The sample can be manually injected into the sample loop, and the system will automatically switch the sample valve to Inject position at user defined time to fulfill the sample injection logic.

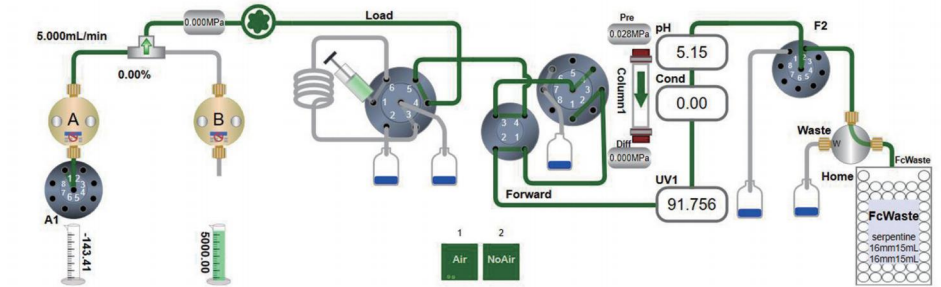

When the injection sample size is over the limit of sample loop, the sample can be directly injected using the system pump. The system pump injection can be controlled via fixed volume or In-line bubble detector signal (if equipped). Operators only need to pre-define the condition during method editing.

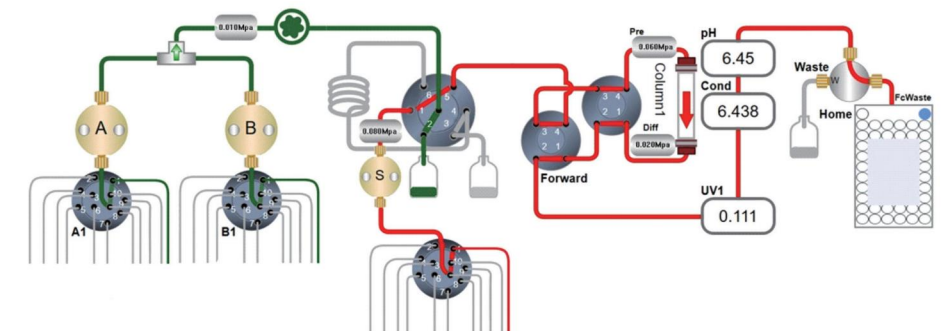

When there are multiple samples and the sample size is over the sample loop limit, if via system pump is not an option, the user can use sample pump (if equipped) to fulfill the need. As same as the system pump, the sample pump also supports control via fixed volume or In-line bubble detector signal (if equipped). Operators only need to pre-define the condition during method editing.

SCG-PHF Protein Purification System

- The SCG-Phf system is designed to meet the pilot-scale and small-scale production need.
- The system has various configurations to support all you need while the performance is stable to your expectations.
- Powerful SCG operating software offer intuitive and flexible method editor, system controller and data analysis tool. The same familiar user interface as the laboratory development environment for the scale up. Please note that the software is free for upgrade during the product lifetime.
- Can work with various brand chromatography column from domestic or international vendors.
- Can fit in regular chromatography refrigerator.
- SCG-Phf can satisfy gram level or even to kg level production needs.

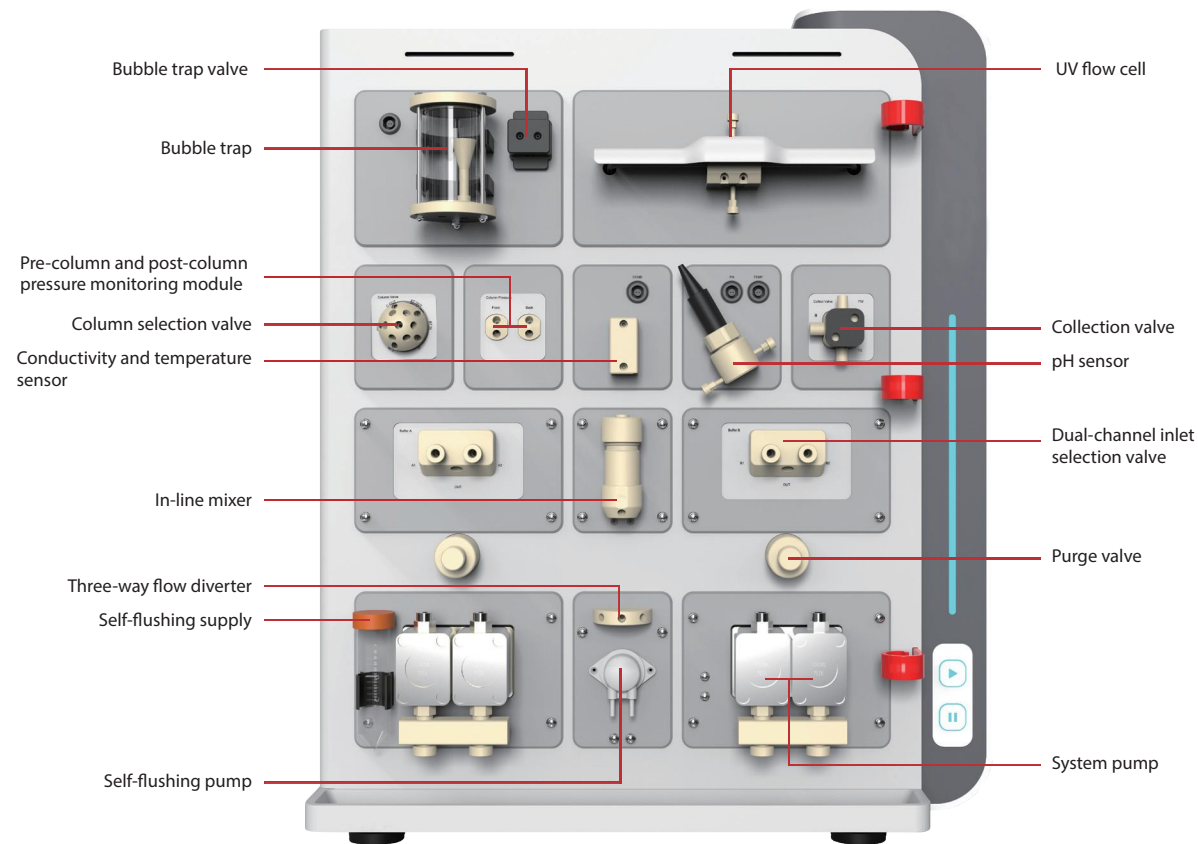
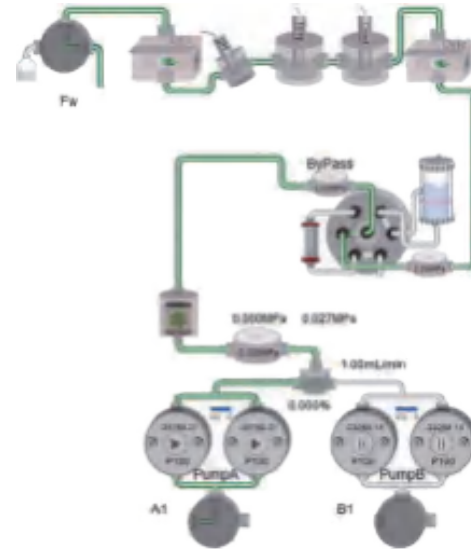

Technical Parameter

Model	SCG-Phf
System pump	Two duo plunger pump, bioinert PEEK/Stainless steel material, good biocompatibility
Flow rate range	0.1 - 999.9 ml/min
System pressure rate	0-2 MPa (20bar, 290psi)
Mixer	15 ml
Flow rate accuracy	± 2%
Flow rate precision	RSD < 0.5%
Supported elution	Isocratic/ramp/step gradient, in-process modification available
Supported elution	200 - 400 nm imported detector, detecting both channels simultaneously. Wavelengths configurable in software, including 2.0mm external flow cell
Wavelength precision/repeatability	±1nm / ±0.5nm
UV noise / drift	0.16mAu (1s) / 1mAu/h
Conductivity sensor	0.001 - 999.99 mS/cm, precision ± 0.1mS/cm or ± 2%
Temperature sensor	0-100 °C, precision± 1 °C, can compensate conductivity/pH result automatically
pH sensor	0-14, precision ± 0.1 (2 - 12)
System operation workstation	SCG operation workstation: in-house designed operation software, brand computer with Win10 operating system
Installation toolkit	PEEK / PTFE pipe, installation manual, user manual, pipe joints, common tools, etc.
Solvent tray	The instrument come with a solvent tray on the top, access easy while saving space
Sample contact material list	PEEK, Stainless Steel, PPS, PTFE
AC input/ power rating	220 VAC/1800 W
Instrument weight (gross weight)	87 kg
Dimension (WxDxH)	590 mm × 730 mm × 530 mm

Optional Configuration

Bubble trap	
Column selection valve	Support column, bypass, airtrap+column, waste
Pre/post column pressure monitoring module	Monitor the pre-/post-column pressure
SCG Phf collection valve	Dual-channel bulk collection valve one channel for waste, one channel for bulk sample collection

SCG Operation Workstation



- Ease of operation ensured by humanized design. The GUI language can be set easily through login screen. Easy to master functions cover all needs without requiring a steep learning curve.
- The software meets GMP / GLP compliancy requirements, also complies with FDA 21 CFR part 11 and CFDA regulations, including User permission control, Audit trail, digital signature and other functions, which ensures data integrity and security;
- Data collected will be display in real-time, including but not limited to time, flow rate, UV, pH, conductance, etc.;
- Operation are fully recorded in LOGBOOK. User can review all historical log and the operation status at any time;
- Over pressure alarm, collection overflow alarm, bubble monitoring alarm and other protection functions available. Real-time alarm response ensures for column and sample safety;
- Real-time data recording, prevents potential data loss, caused by accidental power loss;
- The unique cellphone and tablet remote control function allows user to check the current operating status at any time. The user can monitor experiment anytime in the office area, safer healthier, convenient for operators.



STEP
01

Built In Flowrate

Depending on user's instrument configurations, the flow path will be adjusted accordingly, optimizing your experience.

STEP
02

Flow Path Self-inspection

Built in self-inspection function to verify the correct pipe connection. Avoiding the potential loss of important samples or waste of the column.

STEP
03

Design Experiment

SCG operation workstation provides a powerful, straightforward user interface. It allows you to finish your own experiment design in just few clicks.

STEP
04

Validation Run

The real-time flow path display allows user to easily identify the state of the system.

STEP
05

Data Analysis

Built in data analysis and peak integration module can fulfill the analysis needs easily.

Basic Parameter Setting

- Parameter configuration is located on the top left corner of the control menu. The common parameters include notification, pump, collection, UV sensor, spectrum configuration, pump flushing, simulation setting, etc.

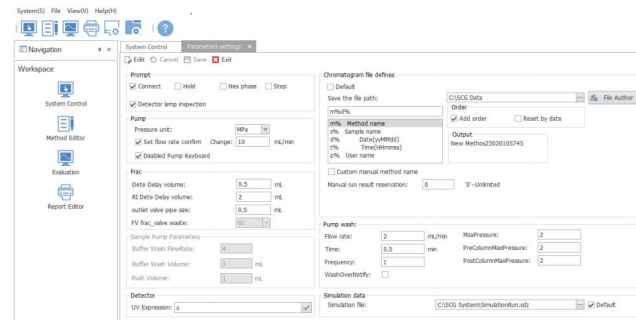

Parameter Setting-notification:

- After the corresponding option is checked, there will be a prompt message to confirm the operation.
- If the connection is checked, a message will be prompted before initialization.
- Other options are hold: prompt before execute hold command; next stage: prompt before execute next stage command; stop: prompt before execute stop command; Deuterium lamp check: whether to check if the deuterium lamp is turned off.



Parameter Setting-injection Pump:

- Pressure unit:** MPa, PSI, bar upon need
- Flow speed setting confirmation:** whether notify user if the current flow speed exceed the set value. To prevent accident user
- Disable pump control interface:** (Only applicable for SCG), whether disable the external button on the instrument. (Recommend to check)

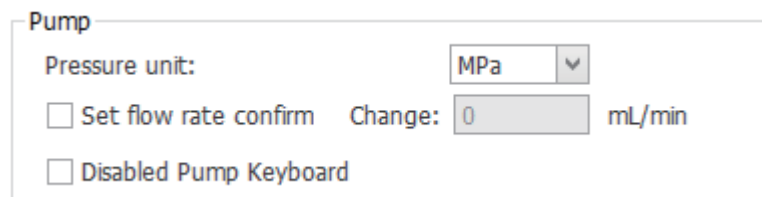

Parameter Settings - Result File Definition:

- File save path:** The default result save path(customizable). Please note that the manual run results are saved in the Manual folder under the save path.
- Access authorization:** (only available for administrator) Allows other users to view data created by administrators.
- Results naming format:** default format name + date + 5-bit serial number (recommended)
- Custom method name:** If checked, prompt user to enter a name instead of default name.
- Manual retention result:** The maximum number of manual results, 0 (recommended) indicates unlimited. When the max number is reached, the data storage will "loop" over to allow the new record overwriting over the oldest files.

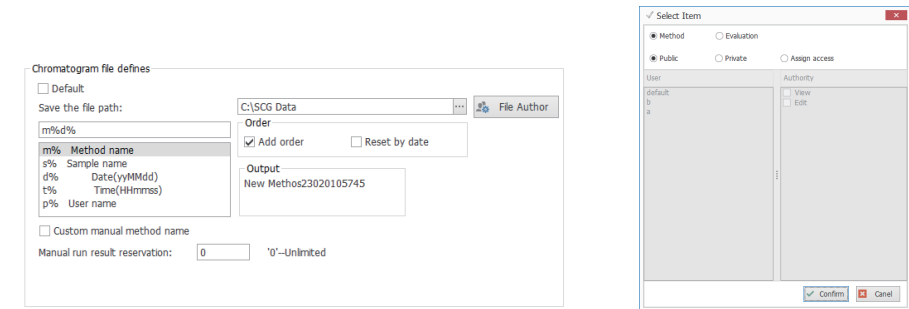

Parameter Settings-pump Flushing:

- Set the flow rate, run time, repeat times and maximum pressure during the pump flushing.

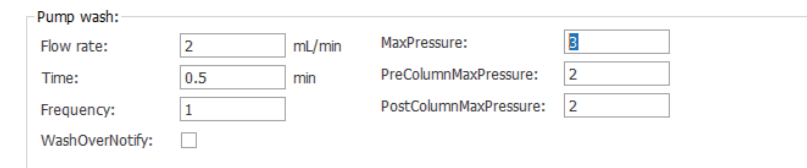

Parameter Setting-sample Pump Parameters:

- If equipped with sample pump, the sample pump buffer flush flow rate need to be configured. Flush volume, sample injection volume are the default values based on pipe length and pump type.

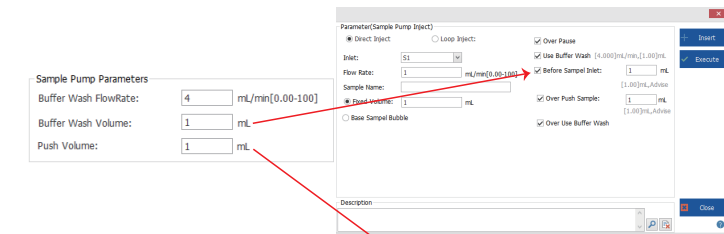

Sample loading refers to injecting the remaining sample in the pipeline into the chromatographic column after the completion of injection volume injection. The loading volume is the remaining sample volume in the pipeline, namely "the pipeline volume from the sample selection valve to the pump+the pipeline volume from the pump dead volume to the sample injection valve".

Permission Setting Menu

- In the task navigation bar, select the system management, where the user and permission setting functions are located. There are three modules: department definition, user definition, and role definition.
- Department definition:** You can preset the user department. After being defined, it can be directly applied to user definition.
- User definition:** You can add/modify users, set user permissions, file permissions, login password, signature password, enable/disable an account.
- Role definition:** Set up the user rights of a role, and then directly carry over when defining other users. For example, when multiple user rights are the same, this method can simplify the setting process.
- The system has pre-set permissions for 5 roles and does not support changes to those. Users can add/choose according to their permission assignments.
- Note:** Department definition and role definition are both to simplify repeating operations of user definition. They can also be manually changed during user defining process.

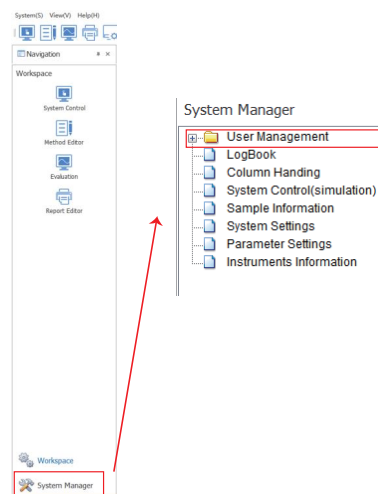

Department Definition:

- You can define a department as needed and set the department's name, number, remarks and other information.
- Add:** After selecting a department category, click Add, enter relevant information, and save to add a new department. If you need to set a sub-department, select the parent department and click Add. After saving, the child department will be in the parent department directory.

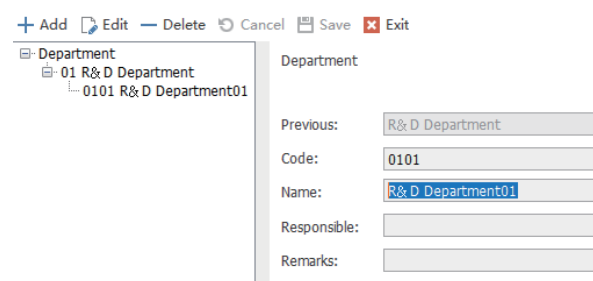

- Reference:** When user-defined, after selecting the department number, the option can be directly selected in the pop-up window, and the department code and department name will be filled in automatically.

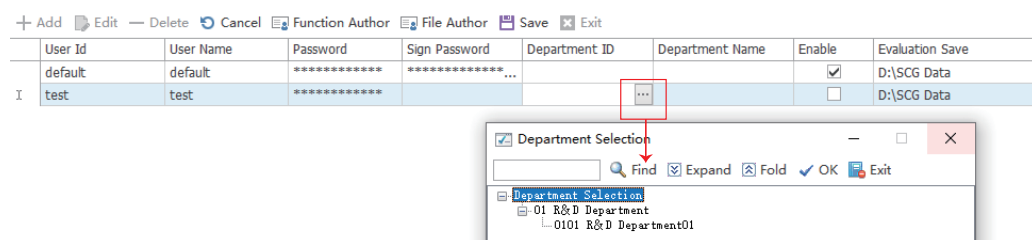

User Definition:

- User definition is the core function of user management. This module can set user-related information, permissions, and enable or disable accounts.
- User code / User name:** according to the entered input.
- Password:** This is the login password, which can be modified after initial use of the preset password. When a user logs in after the initial use, the system will prompt to change the password.
- Signature password:** Set the initial password for future signing use, which can also be modified when the user logs in later. Department code / Department name: It can be entered separately, or it can be edited and referenced in the user management.
- Whether to enable:** Disable if the user is no longer allowed for access. User cannot be removed if it has operation records in the system.
- Result path:** It can be set here or set in parameter settings after user login.
- Function authorization:** Set the permissions for the current account. If the role is carried over, modification is not required. However it is recommended to update the role to reflect accurately. For individual users, it is recommended to set directly in the function authorization instead of applying an existing role.
- File permissions:** Set whether the results and methods from the current user can be opened by other users, and whether those can be edited. Public allows other accounts to view/edit; while Private forbids other accounts from view/edit by others.

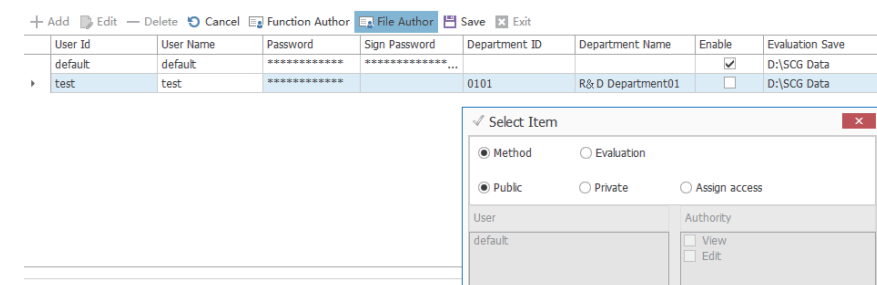

Role Definition:

- Roles can be pre-defined as needed. By default, five roles are defined in the system: Power User, User, Process Supervisor, Process Operator, and Guest. Certain permissions are customized and cannot be modified.
- If the above permission levels do not match with the actual requirements, users can set the permission levels by themselves, that is, set a role for each level, and the number of levels can be customized according to their needs. To set a custom role, do the following:
 - Using Add, enter the code and name of the role in the new line
 - Click Authorize to set the permissions of the current user and click Save after the settings are complete.

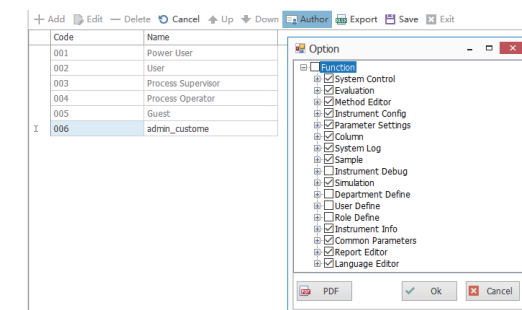

Manual Command

- **Injection pump:** settings related to pump operation
- **Flow path:** Switch flow path
- **Detection:** UV and pressure sensor settings
- **Collection:** Collection related settings
- **Insert:** Insert commands to wait for being executed later
- **Execution:** Run a single instruction or insert multiple instructions instrument
- **Cancel:** Close the manual window
- **Other:** Other options, schedule for pause, stop, column volume, diameter, etc. settings

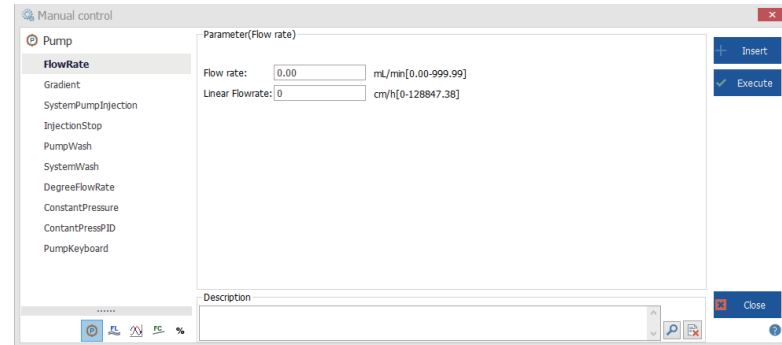

Flow Control Command:

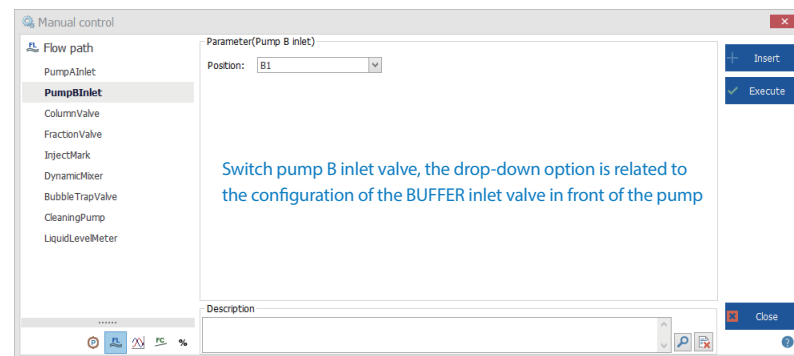
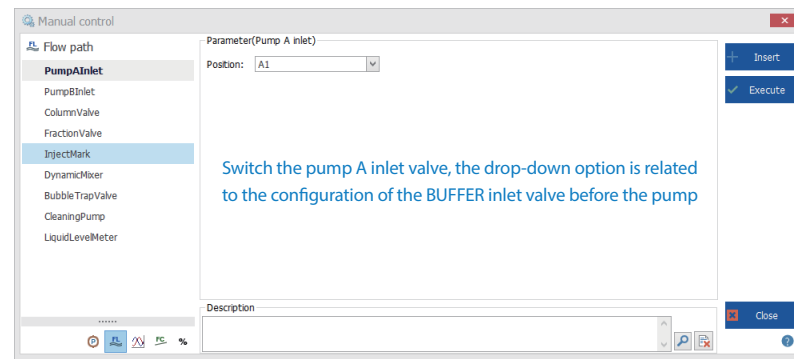

Sensor Command (Commonly Used):

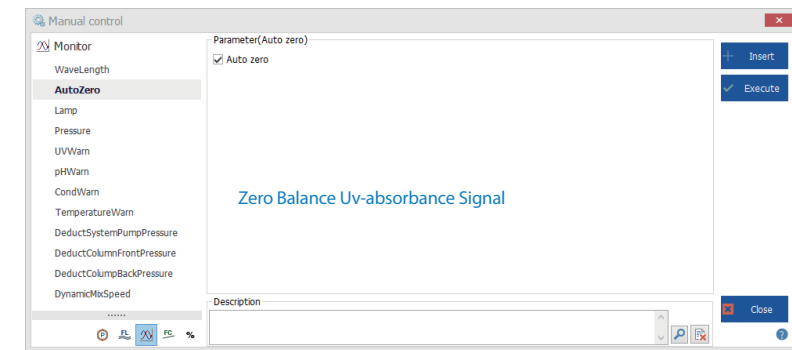
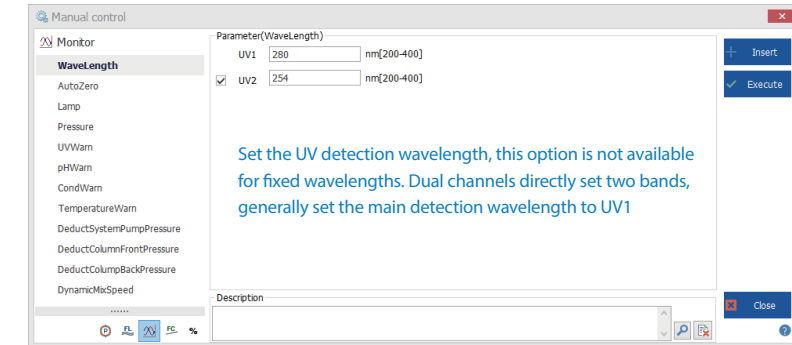

Collection Commands:

- **Collection method:** Fraction collector collection and valve collection channel can be selected. Valve collection generally starts from the third position. The first two positions are used as waste liquid and connected to the fraction collector.
- **Detection Signal:** Fixed volume collection is not useful and does not need to be selected.
- **Start from:** The location where the first fraction is collected, you can specify the location or the next tube/next row, etc. For new experiment recommends emptying the collector to start from the first tube.
- **Number of collections:** How many tubes (channels) will collect in this collection.
- **Volume:** how much volume is collected in each tube (channel), the valve collection method has the option to ignore the volume setting. Will collect fraction that meets the current conditions.
- **Final position processing:** When all the collection tubes (channels) of the instrument are full, and the actual collection number is still not reaching the target number set above, the system processing method can choose to collect the remaining collection number at the specified position or pause. It is recommended to select pause.
- **Delayed trigger:** After the collection condition is met, the fixed volume delayed before actual collection.

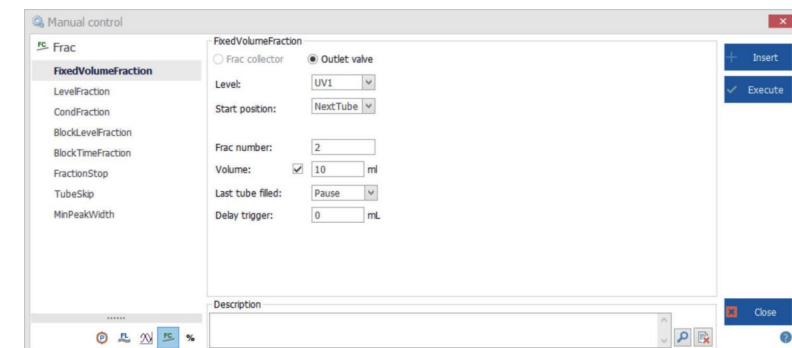

Method Editing Function

- The method can be edited in advance and then referenced directly on the instrument control interface, including the editing of the SCOUTING method.

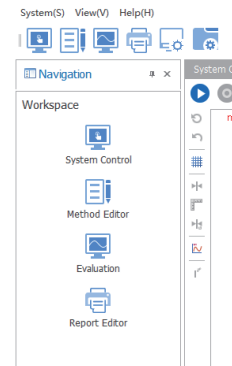

Method Templates – Overview:

- After it is entered and saved in the method interface, this method will become a Scouting method, which contains 3 Runs. The run1, run2, and run3 will be executed in sequence during runtime.

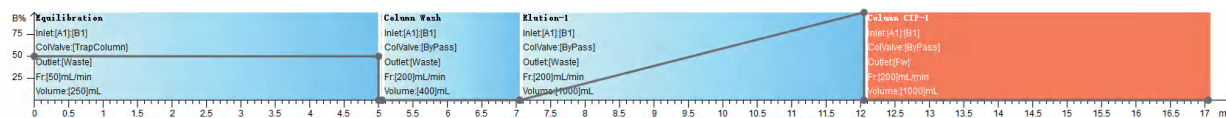

Method Template-scouting:

- After it is determined and saved in the method interface, this method will become a Scouting method, which contains 3 Runs, run1, run2, and run3 will be executed in sequence during runtime.

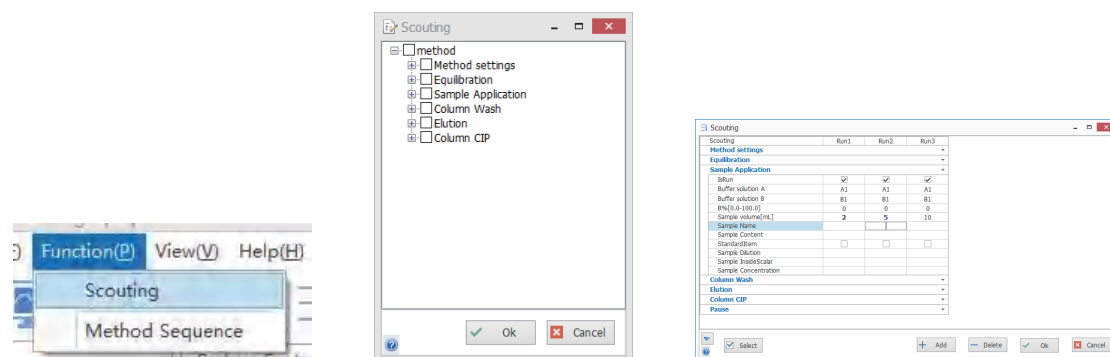

Select the Scouting function in the method screen

Check the modules or parameters that need to be changed

Click "fill in" to increase the number of run and change the parameters to be modified

Method Run:

- After a method is edited, it can be called directly from the instrument control interface to execute

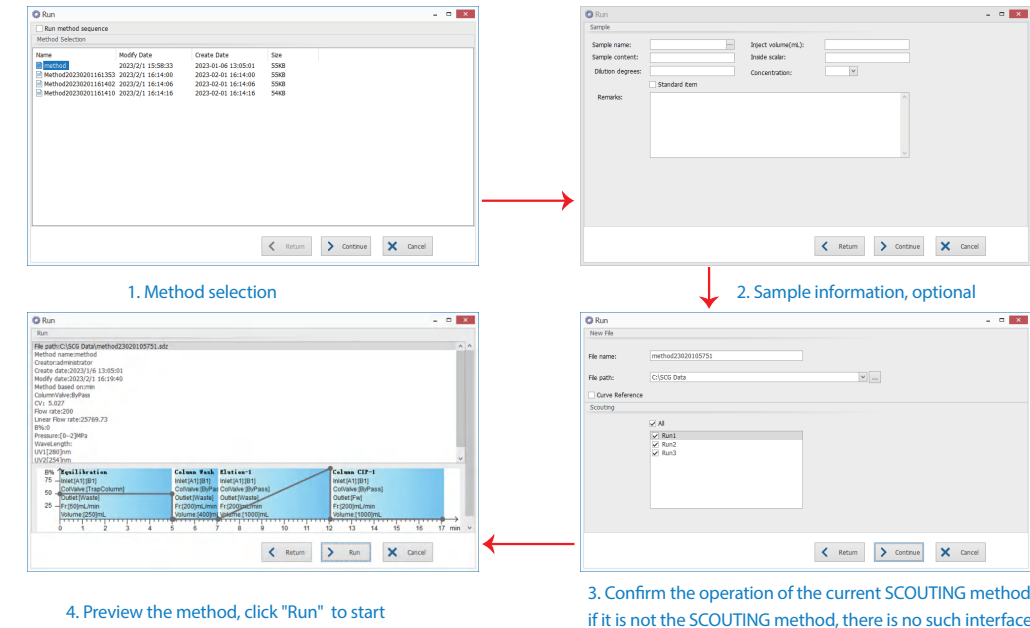

1. Method selection

2. Sample information, optional

4. Preview the method, click "Run" to start

3. Confirm the operation of the current SCOUTING method, if it is not the SCOUTING method, there is no such interface.

Method Sequence Run:

- After a method is edited, it can be called directly from the instrument control interface to execute.

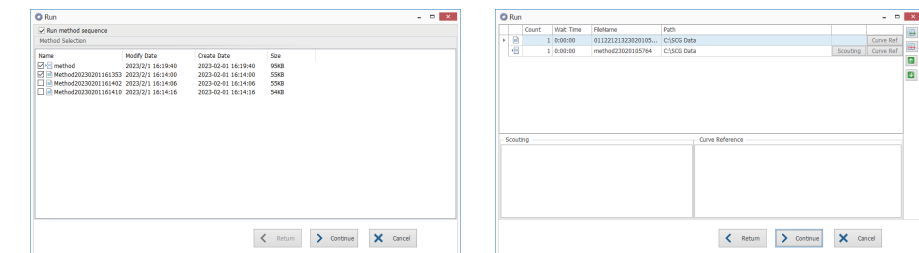

Editing Of The Method Sequence :

- When running a method, there will be a "method sequence" option in the menu bar. In the method sequence interface, you can add, delete, and modify methods (effective for current run use). If you want to modify it permanently, you need to go into the method editor, to do so and then call the saved method to execute.

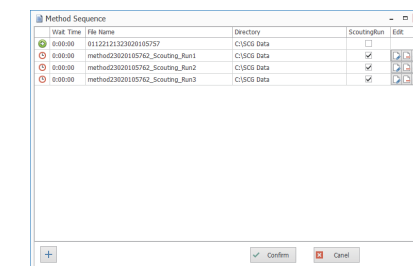

Integration And Reporting Features

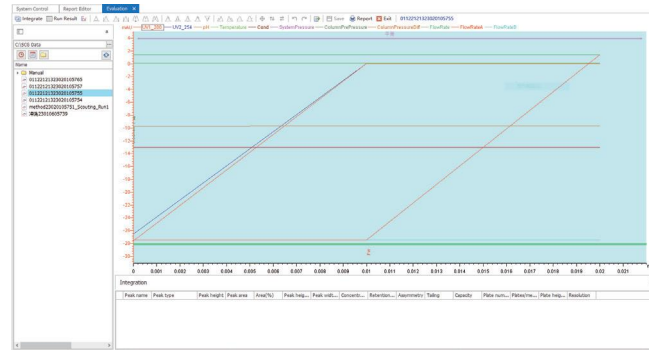

Integration Conditions And Self-service Integration:

- **Minimum Area:** The minimum peak area specified for a peak to be integrated.
- **Minimum peak height:** The minimum peak height required for a peak to be integrated. It is "and" condition with the first parameter: The final integrated peak needs to satisfy both the minimum peak height and the minimum peak area.
- **Algorithm:** Use the default start-end method, no need to select
- **Non-retained peak:** the x-axis location corresponding to the sample injection point, for the involved column efficiency calculation use. The actual retention time used in the column efficiency calculation = the coordinate of the detected peak position - this non-retention value.
- **Column length:** When calculating the column efficiency per meter, through this value conversion, the column efficiency per meter = 1000*column efficiency/column length (*1000 converts the unit to meters).
- **Number of smoothing points:** In order to reduce the impact of UV fluctuation on the identification of peaks by the system, the number of smoothing points can be set. Generally, the end point of automatic integration is at the fluctuation position of the peak. This can be used for other options (or not used).
- **Slope inflection point and threshold:** If selected, the software will detect when the UV absorbance change exceeds the set threshold value at the position of the curve inflection point. If the detected is over the set threshold value, it will automatically integrate as for two peaks.

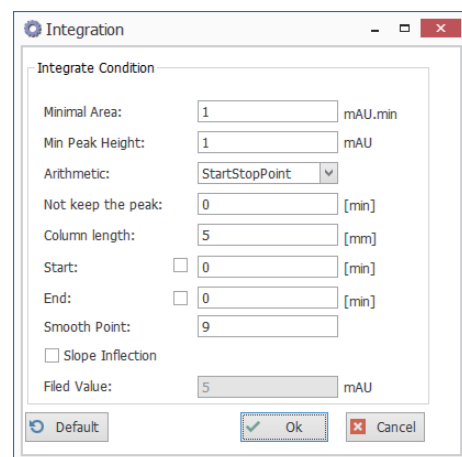

- * Set the integration conditions, you can achieve automatic integration according to the setting.
- * The integration conditions of each method will be saved when the system opens the result file generated by the same method next time, and the previously set integration conditions will be automatically recalled.

Integration Conditions And Self-service Integration:

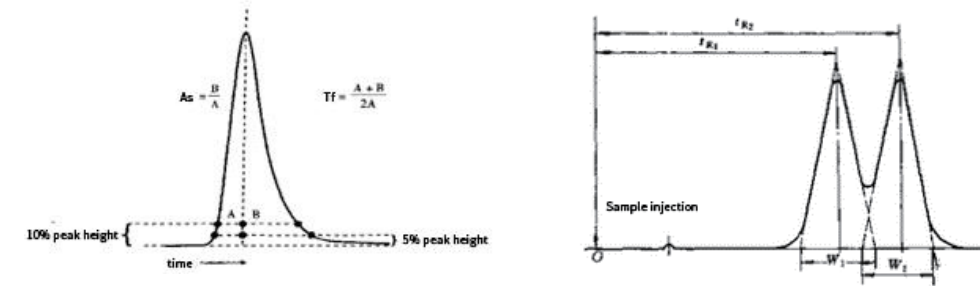

- **Asymmetry (As):** The ratio of B over A as shown. At the 10% of the peak height the intersection of the vertical peak height line with the horizontal line is the point where B and A meets.
- **Tailing factor (Tf):** As shown, the only difference is in the determination of the B and A values. It is the ratio of the peak width at 5% of the peak height instead, to the two times of the value A.
- **Capacity:** Indicates the time ratio between the interested fraction retention in column over the non-retained fraction. However, this value may be meaningless since the non-retention time cannot be determined in the software.
- **Number of plates:** Also known as column efficiency, calculated using the FWHM and retention time, The calculation formula is $R = \frac{2(t_{R2} - t_{R1})}{W_1 + W_2}$
- **Number of plates/meter:** Also known as column efficiency per meter. The calculation is the number of plates divided by column length.
- **Resolution:** The elution time ratio between the two adjacent peaks over the average peaks width of the two. The calculation formula is: $N = 5.54 \left(\frac{t_R}{W_{1/2}} \right)^2$, is the retention time of the second peak, t_{R1} is the retention time of the first peak, W_1 W_2 is the peak width of the adjacent two peaks.

Common Functions Of The Report:

- Running information contains username, file name, date information.
- Right-click on the chromatogram graph and select "Edit Chromatogram" to edit the properties of the chromatogram in the report.
- In edit mode, the log does not show specific content.

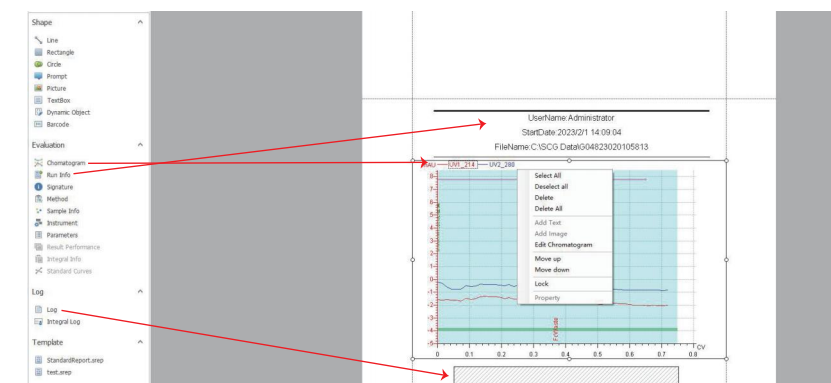

Application Case Study

Samples: Monoclonal Antibody

- Resins type: UniMab 50HC
- Mobile phase: Buffer A :20mM PB+150mM NaCl pH 7.4
- Buffer B: 20mM PB+1M NaCl pH 7.4
- Buffer C: 20mM PB pH 7.4
- Buffer D: 20 mM NaAc-HAc pH 3.6

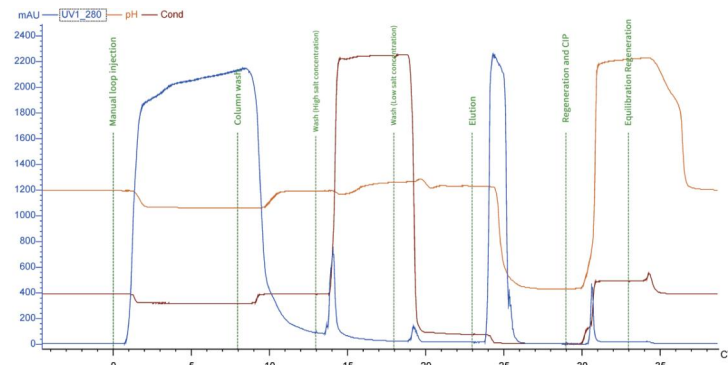

Sample: Fc Fusion Protein

- Resins type: NanoGel 50SP HP
- Mobile phase: Buffer A: 20 mM NaAc-HAc pH 4.5
- Buffer B: 20 mM NaAc-HAc+0.5M NaCl pH 4.5
- Buffer C: 20 mM NaAc-HAc+ 1M NaCl pH 4.5

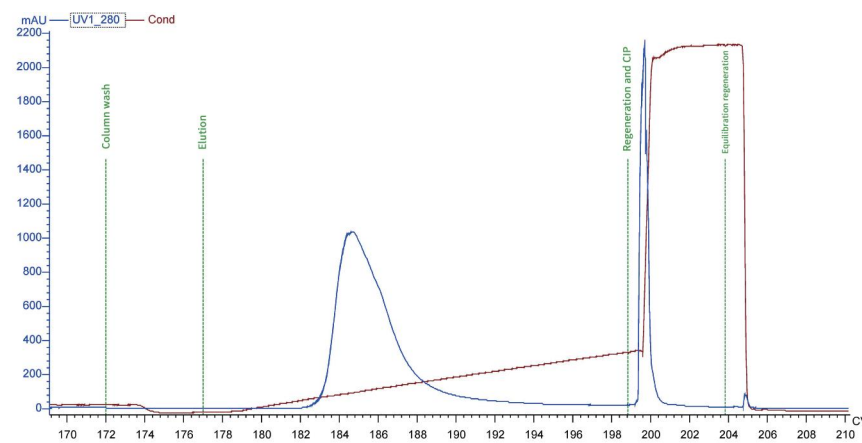

Sample: Albumin

- Resins type: UniHR Butyl 30L
- Mobile phase: Buffer A :20mM PB pH 7.0
- Buffer B: 0.5M NaOH

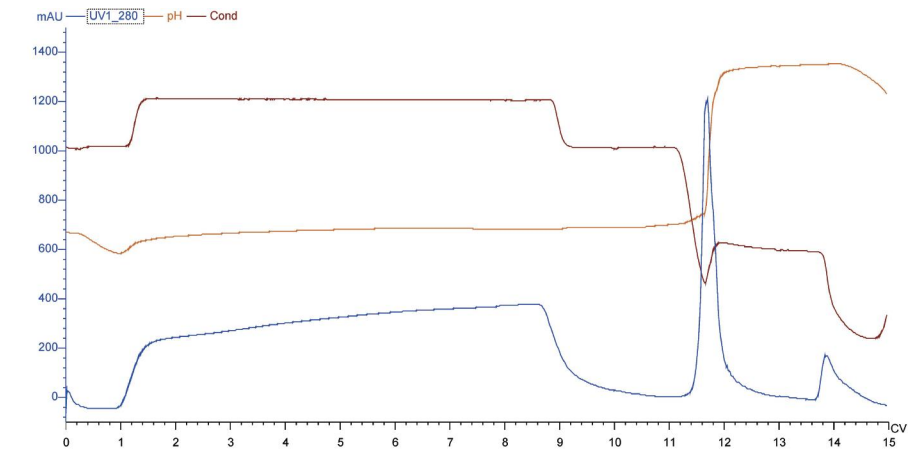

Sample: Fc Fusion Protein

- Resins type: UniGel 80Q
- Mobile phase: Buffer A: PW pH 5.0
- Buffer B: 0.2M NaCl pH 5.0

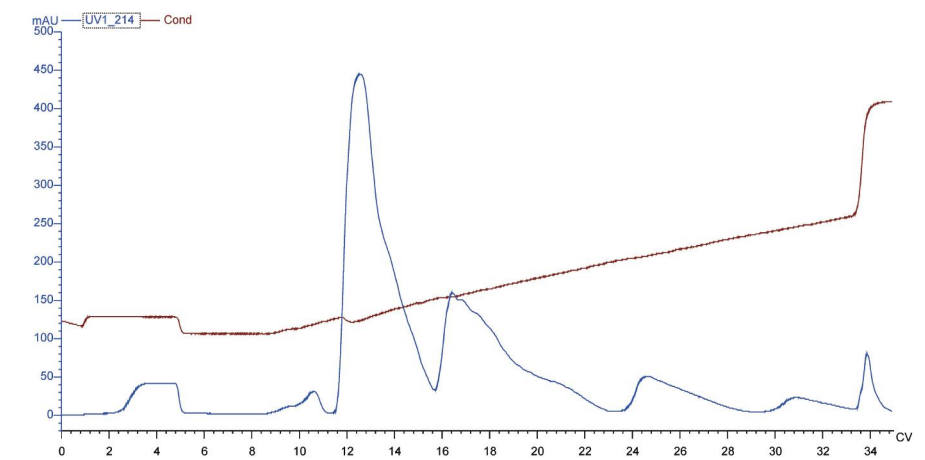

Application Case Study

Sample: Recombinant Protein

- Resins type: NanoGel 50SP
- Mobile phase: Buffer A: 20 mM NaAc-HAc pH 4.5
- Buffer B: 20 mM NaAc-Hac+1M NaCl pH 4.5

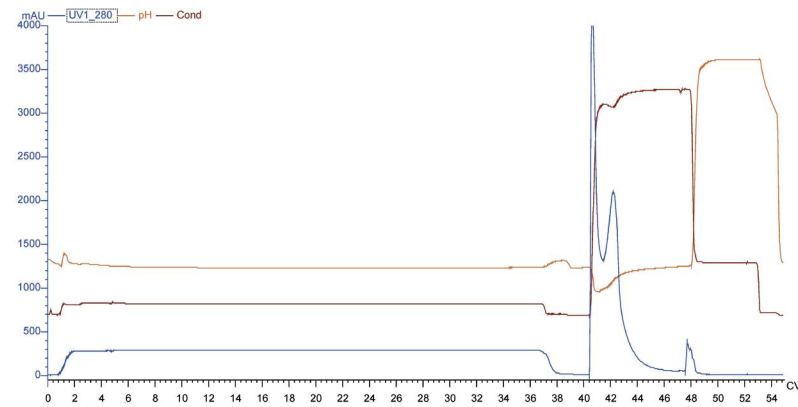

SAMPLES: MONOCLONAL ANTIBODY

- Resins type: NanoGel 50SP HP
- Mobile phase: Buffer A: 20 mM NaAc-HAc pH 5.0
- Buffer B: 20 mM NaAc-Hac+0.4M NaCl pH 5.0

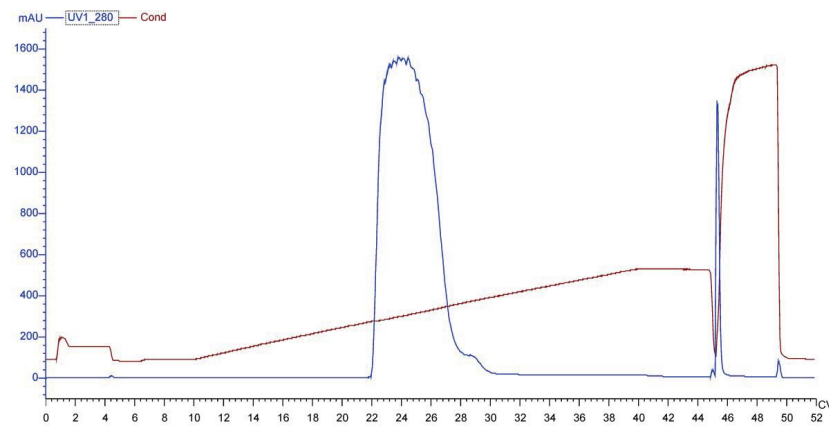

SAMPLE: BISPECIFIC ANTIBODY

- Resins type: UniGel 50HC
- Mobile phase: Buffer A :50mM Tris+150mM NaCl pH 7.4
- Buffer B: 50mM Tris+0.5M Arg-HCl pH 7.4
- Buffer C: 50mM NaAc-HAc pH 5.5

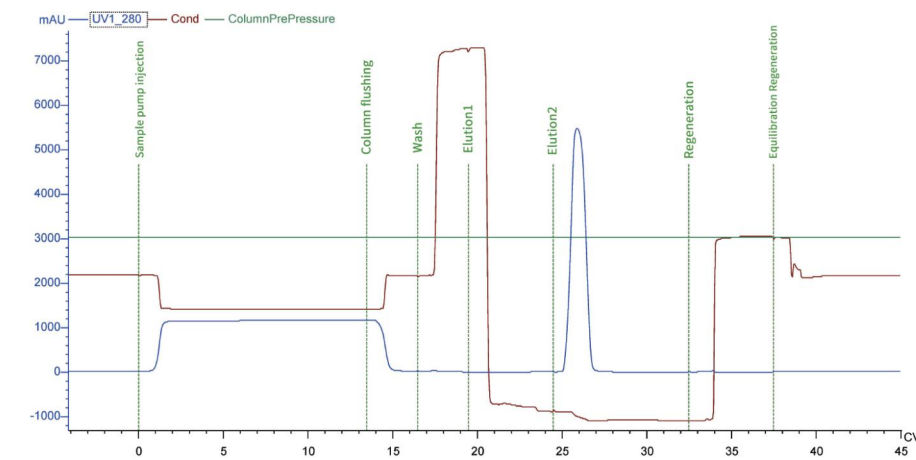
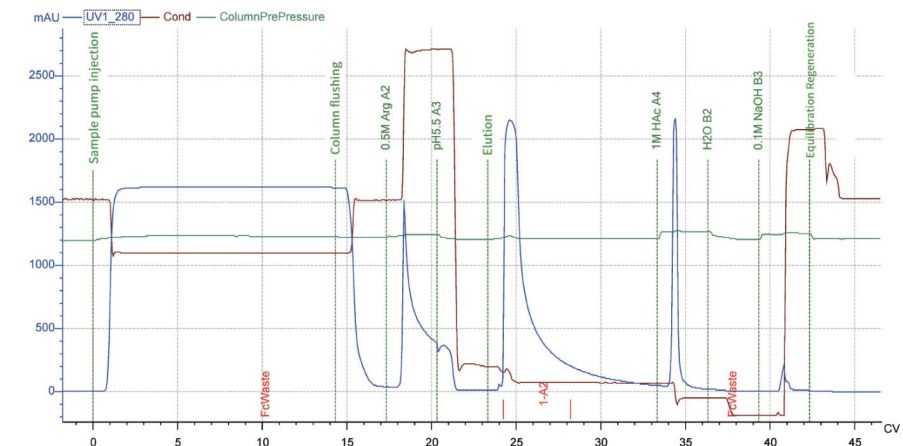

Oligonucleotide Synthesis System (STS)

- STS is an integrated, fully automated phosphoramidite DNA/RNA oligonucleotide synthesis system. STS can be used to synthesize the scale from 50 μmol to 9 mmol. The system is driven by a high-precision liquid pump. With precise reaction speed and contact time control, the carefully designed flow path control can significantly reduce the waste of amidite and other reagents. The unique one-button switch cycling mode meets the DNA/RNA synthesis need ensuring low-cost, high-efficiency, and high-quality synthesis results

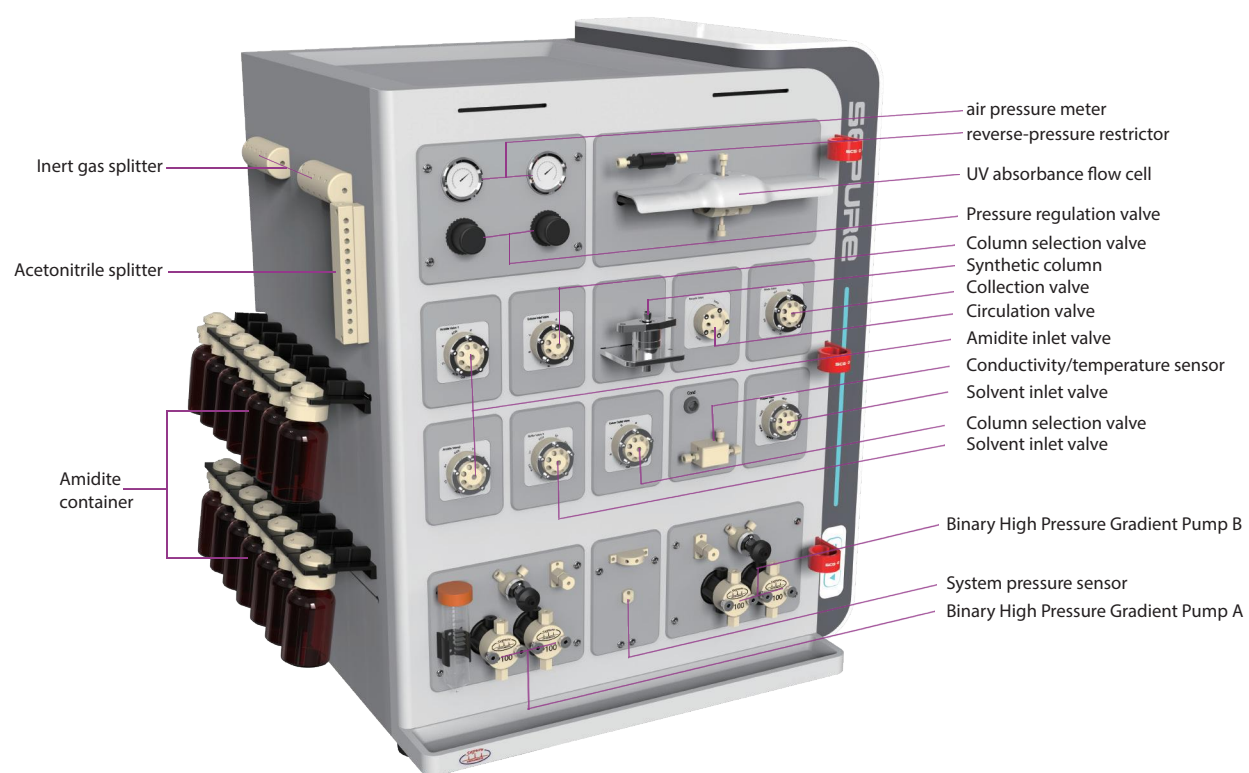

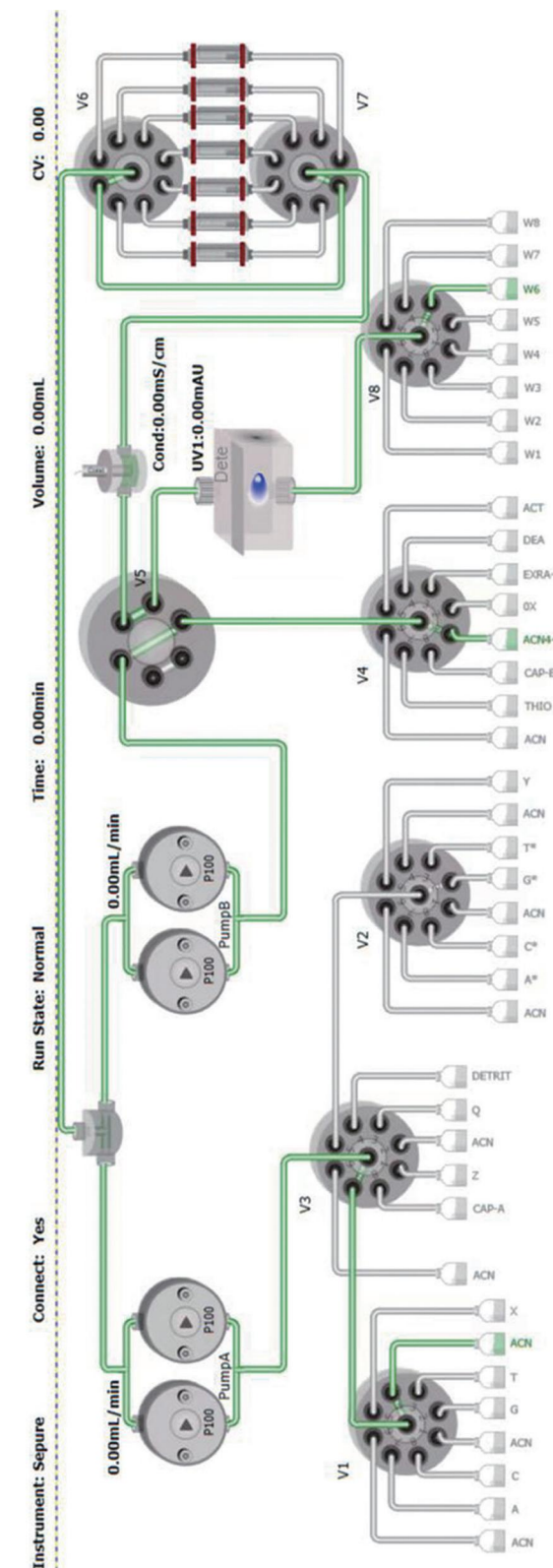

Configuration And Parameter

Model	TrueSynt
Synthetic Amount	50 μmol -9mmol
Coupling Efficiency	>98%
UV absorbance detector	4 channel wavelength selection from range 200-800nm simultaneously
System pressure rate	2Mpa
System pump type	Plunger pump
Flow rate	$\leq 2 \times 100 \text{ ml/min}$
Number of column reactors	7
Circulation path	support
Number of amidite entrance	12 (Standard)
Number of waste outlet	8
System protection	Inert gas protection
Control System	STS Oligonucleotide Synthesis Workstation
Installation Toolkit	PEEK/PTFE pipe, installation manual, user manual, pipe joints, common tools, etc.
AC inlet/Power	220VAC/600W
Dimension (WxDxH)	690x740x530

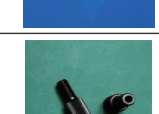

#	picture	name	number
1		1/8in solvent filter	0103-0815-00
2		1/8in solvent filter seal	0103-0814-00
3		20PSI back pressure regulator	0105-0003-00
4		Deuterium lamp	0104-4812-00
5		Tub PEEK Nat 1/16x.040x100ft	0106-0602-00
6		Tub PEEK Grn 1/16x.030x100ft	0106-0504-00
7		Tub Tflz Nat 1/16*0.03*100ft	0106-0516-00
8		Tub Halar 1/8*1/16*50ft	0106-0815-00
9		Tub PFA Nat 1/16*0.40*50ft	0106-0612-00
10		Tub PFA Hi Pur 3/16*0.125*100ft	0106-0319-00
11		10-32 barrel connector	0103-4802-00
12		10-32 Plug	0103-4821-00
13		1/8 peek nut	0107-1607-00

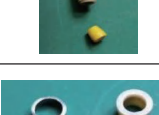
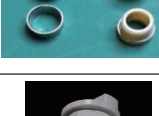
#	picture	name	number
14		3/16 PEEK nut	0107-1608-00
15		Flangeless Ferr 3/16in Tefzel Blue	0107-1612-00
16		1/16 high pressure PEEK nut	0107-0214-00
17		1/16PEE Knut	01-07-006-001
18		Fngls Sys Blk Delr 1/16in	0107-0225-00
19		Fngls Sys Short PEEK 1/8in	0107-0226-00
20		Fngls Sys PEEK 1/8in	0107-0330-00
21		Sprlangel Ferr PEEK 1/8in	0107-0833-00
22		On-line Filter	0803-0001-00
23		Injection adaptor	0107-0216-00
24		1ml sample loop	0709-0004-00
25		2ml sample loop	0709-0005-00
26		5ml sample loop	0709-0006-00